

Review

Versatile hemidesmosomal linker proteins: Structure and function

Pratik R. Chaudhari and Milind M. Vaidya

Advanced Centre for Treatment, Research and Education in Cancer (ACTREC), Tata Memorial Centre, Kharghar, Navi Mumbai, Maharashtra, India

Summary. Hemidesmosomes are anchoring junctions which connect basal epidermal cells to the extracellular matrix. In complex epithelia like skin, hemidesmosomes are composed of transmembrane proteins like $\alpha 6\beta 4$ integrin, BP180, CD151 and cytoplasmic proteins like BPAG1e and plectin. BPAG1e and plectin are plakin family cytolinker proteins which anchor intermediate filament proteins i.e. keratins to the hemidesmosomal transmembrane proteins. Mutations in BPAG1e and plectin lead to severe skin blistering disorders. Recent reports indicate that these hemidesmosomal linker proteins play a role in various cellular processes like cell motility and cytoskeleton dynamics apart from their known anchoring function. In this review, we will discuss their role in structural and signaling functions.

Key words: BPAG1e, Cancer, Cytoskeletal proteins, Hemidesmosome, Plectin

Introduction

Anchoring junctions connect the cytoskeletal elements of a cell to those of its neighboring cell or to the extracellular matrix. Desmosomes (DSs) are cell-cell anchoring junctions, whereas hemidesmosomes (HDs) are a type of anchoring junctions which connect the basal surface of epithelial cells to the underlying basal

lamina. Ultrastructurally, HDs are composed of an electron dense structure whose cytoplasmic plaque anchors keratins (intermediate filament proteins) to the cell surface (Jones et al., 1998; Borradori and Sonnenberg, 1999). Depending upon the protein composition there are two types of HDs, type 1 HDs and type 2 HDs. Type 1 HDs, present in complex epithelia like skin, are comprised of $\alpha 6\beta 4$ integrin, BP180 (BPAG2; XVII collagen), tetraspanin CD151 and cytoplasmic linker proteins: plectin and BP230 (BPAG1e: Bullous pemphigoid antigen 1e). Type 2 HDs which are majorly found in simple epithelia consist of $\alpha 6\beta 4$ integrin, plectin and CD151 (Jones et al., 1998; Nievers et al., 1999; Sterk et al., 2000; de Pereda et al., 2009a). Mutations in hemidesmosomal proteins lead to severe skin blistering disorders. Apart from their anchoring function, HDs play a role in both inside-out and outside-in signal transduction mediated by $\alpha 6\beta 4$ integrin component (Jones et al., 1998). In the case of type 1 HDs, BPAG1e and plectin anchor keratin proteins to the cell surface via $\beta 4$ integrin (Jones et al., 1998; Borradori and Sonnenberg, 1999). Ablation of these linker proteins in mice resulted in severe skin blistering (Guo et al., 1995; Andra et al., 1997). A few reports suggest that plectin and BPAG1e play a role in various cellular processes (Andra et al., 1998, 2003; Hamill et al., 2009, 2011; McInroy and Maatta, 2011; Katada et al., 2012; Valencia et al., 2013; Michael et al., 2014; Sutoh Yoneyama et al., 2014). However, not much literature is available related to the functions of these proteins. In this review, we will focus on hemidesmosomal linker proteins namely plectin and BPAG1e which are part of the plakin family of

Offprint requests to: Milind M. Vaidya, Advanced Centre for Treatment, Research and Education in Cancer (ACTREC), Tata Memorial Centre Kharghar, 410210, Navi Mumbai, Maharashtra, India. e-mail: mvoidya@actrec.gov.in

cytolinker proteins. Further, we will discuss structural and functional details along with cellular interactions of these proteins. Additionally, we will briefly describe the existing literature regarding involvement of hemidesmosomal linker proteins in blistering diseases of skin and other diseases like cancer.

Structure of HDs

HDs are located at the basal side of epithelial cells where they connect the extracellular matrix to the intermediate filament proteins. In complex epithelia like skin, type 1 HDs are present which are comprised of the transmembrane proteins like $\alpha6\beta4$ integrin, BP180 and CD151 which form the outer plaque of HD. The inner plaque of HDs is formed by cytoplasmic linker proteins called BPAG1e and plectin (Stepp et al., 1990; Sawamura et al., 1991; Hieda et al., 1992; Jones et al.,

1998; Nievers et al., 1999; Sterk et al., 2000; de Pereda et al., 2009a). These linker proteins connect intermediate filament proteins to the transmembrane proteins, which in turn interact with extracellular matrix protein laminin 5 (Fig. 1).

Plakin family proteins

Plakins are cytolinker proteins that connect cytoskeletal elements to junctional complexes such as desmosomes and hemidesmosomes. To date seven plakin family members have been identified: desmoplakin, plectin, bullous pemphigoid antigen 1, envoplakin, periplakin, epiplakin and microtubule actin crosslinking factor (reviewed in Leung et al., 2002). The N-terminal plakin domain is a defining feature of plakin family proteins (except epiplakin). The plakin domain is composed of a number of subdomains designated as NN,

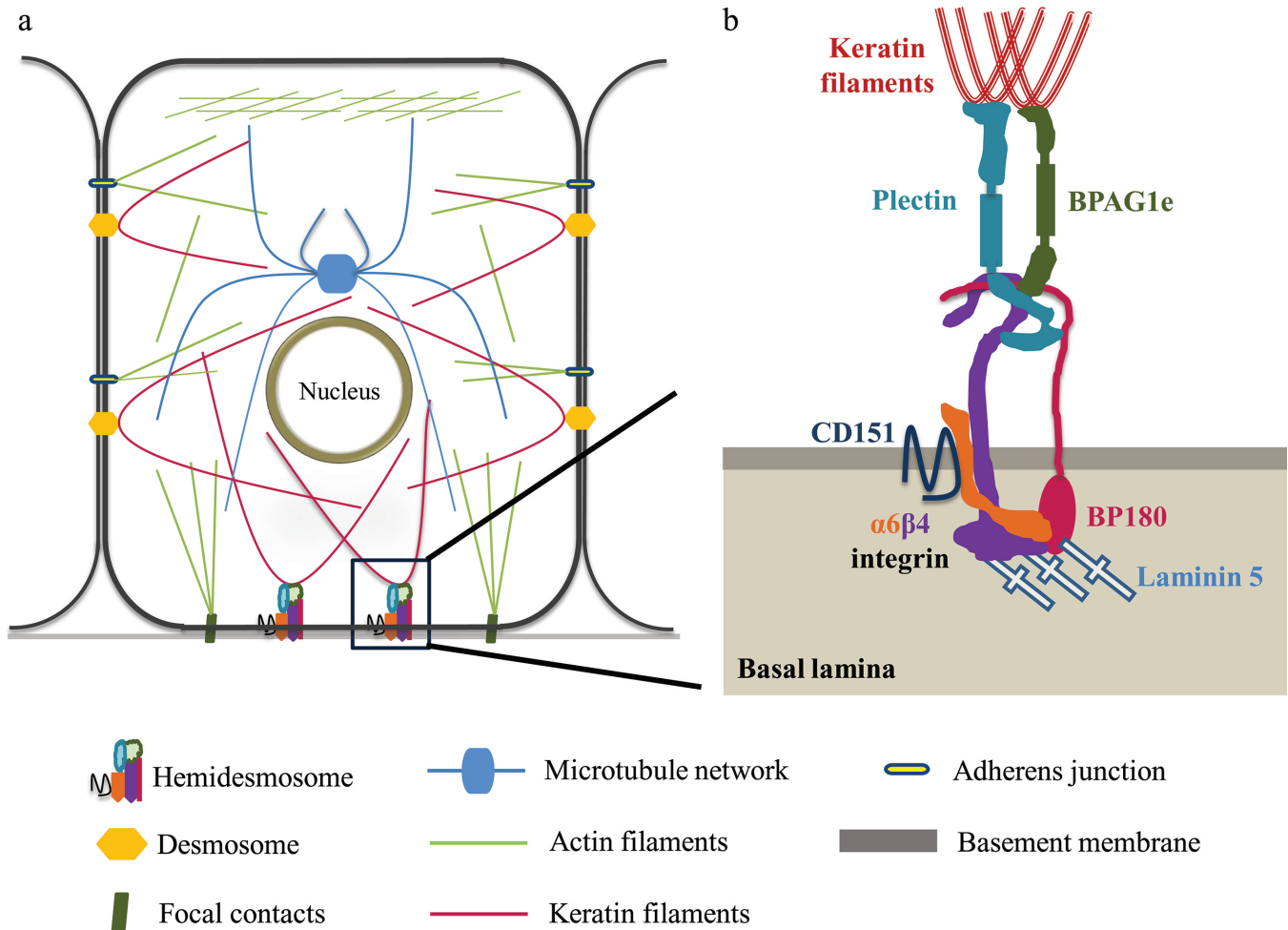

Fig. 1. Structure of Hemidesmosome. **a.** Junctional complexes and cytoskeletal elements present in basal epidermal cells; **b.** schematic representation of hemidesmosomal components. $\alpha6\beta4$ integrin, BP180 and CD151 form the outer plaque while BPAG1e and plectin form inner plaque of hemidesmosomes. Hemidesmosomes link the extracellular matrix protein laminin 5 to the intermediate filament network.

Hemidesmosomal linker proteins

Z, Y, X, W and V which are rich in α -helical structures. The plakin domain is thought to be important in targeting plakins to specific cell junctions (Koster et al., 2003). The central coiled-coil rod domain, which has heptad repeats, is important for dimerization of plakins. The C-terminus of plakins varies as per plakin type and is composed of either plakin repeat domains (PRD) or spectrin repeats. The PRD consists of one or many A, B, C subdomains which can associate with intermediate filament proteins (Green et al., 1992; Fontao et al., 2003) (Fig. 2).

Hemidesmosomal linker proteins

BPAG1e

BP230 protein, which is encoded by the *DST* gene, has several isoforms, namely BPAG1n, BPAG1e, BPAG1a, BPAG1b based on alternative splicing of the gene. These alternatively spliced products show tissue specific distribution. BPAG1e (306kDa) is a major isoform expressed in epidermis. BPAG1n (344 kDa), also known as dystonin, is present in neurons. BPAG1a (615 kDa) is produced mostly in pituitary primordia and the dorsal root ganglia (DRG). Muscle specific isoform BPAG1b is the largest isoform of BP230 which is about 824 kDa. BPAG1e consists of a coiled-coil rod domain flanked by a plakin domain and a PRD comprising of B and C subdomains. BPAG1e, unlike BPAG1n, lacks N-terminal actin binding domain (ABD) and therefore cannot interact with actin filaments. The B and C subdomains of PRD, including the intervening linker region, are required for the interaction with intermediate filament proteins (Leung et al., 2001; Fontao et al., 2003) (Fig. 2).

Plectin

Plectin is a versatile plakin family member which can associate with all three forms of cytoskeletal proteins. It is expressed in various tissues except for certain neurons (Errante et al., 1994; Elliott et al., 1997). Plectin is encoded by the *PLEC1* gene. Due to alternative splicing of the 5' end of *PLEC1* gene, there are several isoforms of plectin having molecular weight more than 500 kDa. These isoforms show tissue specific expression pattern. For example, 1, 1a and 1c isoforms of plectin are expressed in epidermis. Amongst these plectin 1a is predominant in HDs (Fuchs et al., 1999; Andra et al., 2003; Walko et al., 2011). The N-terminus of plectin has actin binding domain (ABD) by virtue of which it interacts with actin filaments. It has been shown that ABD of plectin preferentially interacts with $\beta 4$ integrin rather than actin (Geerts et al., 1999). Plectin comprises of 6 PRDs (5 B subdomains and 1 C subdomain). C-terminal Glycine-Serine-Arginine (GSR) domain is required for interacting with microtubules (Sun et al., 2001) (Fig. 2).

Interactions mediated by hemidesmosomal linker proteins

The C-terminal plakin repeat domain of BPAG1e and plectin interacts with intermediate filaments whereas the N-terminal plakin domain of these linker proteins interacts with the fibronectin domain of $\beta 4$ integrin (Fontao et al., 2003; Koster et al., 2003; de Pereda et al., 2009b). However, the $\beta 4$ integrin binding site for plectin and BPAG1e is different (Koster et al., 2003). A stretch of 85 amino acids located in N terminus of BP180 is crucial for its binding to plakin domain (Y subdomain)

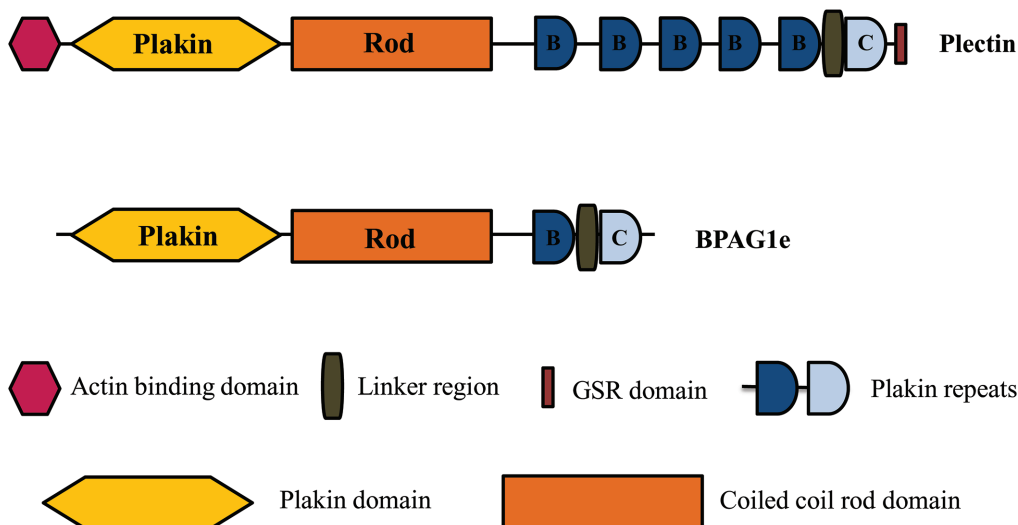

Fig. 2. Structural domains of hemidesmosomal linker proteins. Coiled coil rod domain is required for dimerization of linker proteins; N-terminal plakin domain is important for the interaction with transmembrane proteins like $\beta 4$ integrin, BP180; C-terminal plakin repeat domain and linker domain interacts with intermediate filaments; Actin binding domain of plectin associates with actin filaments; GSR domain of plectin is interacts with microtubules.

of BPAG1e and plectin. The binding sites on BP180 for BPAG1e and plectin are different from those involved in the binding to $\beta 4$ integrin (Hopkinson and Jones, 2000; Koster et al., 2003). There are reports stating the importance of phosphorylation status of plectin in plectin-cytoskeletal protein association. Site specific phosphorylation of serine/ threonine residues of plectin by kinases results in weakening of plectin-cytoskeletal protein association (Skalli et al., 1992; Foisner et al., 1996; Bouameur et al., 2013).

Events involved in HD assembly

Several studies have reported that $\alpha 6\beta 4$ integrin and its ligand laminin 5 play important a role in the assembly of hemidesmosomes (Aberdam et al., 1994; Brown et al., 1996; Dowling et al., 1996; Georges-Labouesse et al., 1996; van der Neut et al., 1996). The large cytoplasmic domain of the $\beta 4$ integrin (over 1000 residues) harbors two pairs of fibronectin type III (FNIII) repeats separated by a connecting segment (CS) and it is essential for the formation of HDs (Murgia et al., 1998; Nievers et al., 1998). The first pair of FNIII repeat and the first 35 residues (1321-1355) of the CS of the $\beta 4$ integrin interact with ABD of plectin, which marks the primary interaction between plectin and $\beta 4$ integrin (Niessen et al., 1997a,b; Schaapveld et al., 1998; Nievers et al., 2000). Furthermore, the plakin domain of plectin also interacts with the C-terminal part of connecting segment and region following fourth the FNIII repeat of $\beta 4$ integrin (Rezniczek et al., 1998). In another study, Nievers et al have shown that plectin is involved in localization of chimeric $\beta 4$ integrin lacking extracellular domain into HDs, suggesting that HD formation can take place in absence of $\alpha 6\beta 4$ integrin-laminin 5 interaction (Nievers et al., 1998). Whether the $\beta 4$ integrin regulates the distribution of plectin to HDs or the plectin is key molecule for localization of $\beta 4$ integrin into HDs is not yet clear. Nevertheless, it is well appreciated from *in vitro* studies that the association of the $\beta 4$ integrin with plectin is crucial for the formation of HDs (Geerts et al., 1999; Koster et al., 2001; Nakano et al., 2001). Interestingly, neither of the BP antigens, BP180 and BPAG1e, gets recruited efficiently into HDs when $\beta 4$ integrin-plectin interaction did not occur (Koster et al., 2003, 2004). These reports confirmed that interaction of the $\beta 4$ integrin with plectin is of prime importance for HD formation to take place and occurs before recruitment of BP180 and BPAG1e.

Sterk et al have reported colocalization of CD151 with $\alpha 3\beta 1$ integrin in pre-hemidesmosomal structures in $\beta 4$ integrin deficient PAJEB cells. On the other hand, $\beta 4$ integrin transfected PAJEB cells showed enhanced surface expression of CD151 along with recruitment of CD151 into HDs (Sterk et al., 2000). This process only occurs when the $\alpha 6$ subunit is associated with the $\beta 4$ subunit. It is possible that incorporation of CD151 into HDs occurs after $\alpha 6\beta 4$ integrin and plectin interaction takes place.

BP180, a type II transmembrane protein, can interact with laminin 5 and $\alpha 6$ integrin by virtue of its extracellular domain while it interacts with $\beta 4$ integrin, plectin and BPAG1e by means of large collagenous cytoplasmic domain (Giudice et al., 1992; Hopkinson et al., 1995, 1998; Borradori et al., 1997; Aho and Uitto, 1998; Borradori et al., 1998; Schaapveld et al., 1998). Reports have demonstrated that efficient localization of BP180 into hemidesmosomes may be dependent on its interaction with both $\beta 4$ integrin and plectin, suggesting that co-operative binding of $\beta 4$ integrin and plectin to BP180 is needed to stabilize HDs (Aho and Uitto, 1998; Schaapveld et al., 1998).

The last step in hemidesmosome assembly is the recruitment of BPAG1e. A stretch of 85 amino acid residues in the cytoplasmic domain of BP180 is crucial for its binding with BPAG1e. The plakin domain (Z-Y domain) contains sequences important for the localization of BPAG1e into HDs most likely via binding to BP180. Further, BPAG1e interacts with the $\beta 4$ integrin to get stabilized into HDs (Koster et al., 2003). There are conflicting reports regarding incorporation of two BP antigens into HDs. One of the studies indicates that BP180 plays important a role in associating BPAG1e in HD plaque. BP180 lacking GABEB keratinocytes form HDs devoid of BPAG1e, indicating that BP180 may play a critical role in coordinating the subcellular distribution of BPAG1e (Borradori et al., 1998). Conversely, transfection studies have shown that BPAG1e can associate with $\alpha 6\beta 4$ integrin even in the case of altered BP180 polarization (Hopkinson and Jones, 2000). Likewise, few other studies have demonstrated that most GABEB patients show BPAG1e distribution at the site of HD inner plaque (Jonkman et al., 1995; McGrath et al., 1995; Chavanas et al., 1997).

Mutational disorders of hemidesmosomal linker proteins

Hereditary skin diseases

HDs provide stable adhesion of epithelia to the basement membrane. Mutations in PLEC1 and DST gene result in a skin blistering disease called epidermolysis bullosa simplex (EBS). Epidermolysis bullosa (EB) is a heterogeneous group of hereditary blistering disorders of skin and mucous membranes. The inheritance of these conditions can be either autosomal dominant or autosomal recessive. EB is divided into three categories: 1. simplex, non-scarring forms of EB (EBS), 2. junctional forms of EB (JEB), 3. dystrophic, severely scarring forms of EB (DEB) (Pearson, 1962). Diseases resulting from mutations in PLEC1 and DST are detailed in Table 1.

Groves et al identified a homozygous truncating mutation in the DST gene encoding the rod domain of BPAG1e which resulted in autosomal recessive epidermolysis bullosa simplex-2 (EBSB2) (Groves et al.,

Hemidesmosomal linker proteins

2010). Another homozygous mutation which affects BPAG1a and BPAG1b but not BPAG1e results in hereditary sensory autonomic neuropathy type 6 (HSAN6) (Edvardson et al., 2012). Several EBS subtypes are reported to be due to mutations in the PLEC1 gene. Amongst these, EBS with muscular dystrophy (EBS-MD) is an autosomal recessive disorder characterized by early childhood onset of progressive muscular dystrophy and blistering skin changes (Niemi et al., 1988; Fine et al., 1991). EBS-Olga is an autosomal dominant disease that is characterized by skin blistering predominantly on the hands and feet. It is caused by a single amino acid substitution in the rod domain of plectin which makes it sensitive to epidermal specific proteases (Koss-Harnes et al., 2002; Walko et al., 2011).

Acquired skin diseases

Bullous pemphigoid (BP) is an acquired skin disease of the dermal-epidermal anchoring junction which is prevalent in elderly individuals. BP is characterized by tense blisters and is usually associated with severe itching (Zillikens, 1999). Jordon et al. demonstrated that BP patients produce circulating autoantibodies directed against antigens located in the cutaneous basement membrane zone. In BP patients, circulating immunoglobulin G antibodies to BPAG1 and BPAG2 are found (Jordon et al., 1967). Using immunoprecipitation and immunoblotting techniques, Stanley et al identified BPAG1e as a major antigenic target of BP autoantibodies (Stanley et al., 1981, 1984; Mueller et al., 1989). Further, 180 kDa protein now termed as BP180 was identified in high percentages of BP sera (Labib et al., 1986) which was further characterized by Nishizawa et al. (1993). Antibodies raised against human BPAG1 and BPAG2 cause skin blistering when injected in neonatal mice (Liu et al., 1993). In summary, BP is caused by autoantibodies and inflammation abnormally accumulating in the basement membrane of the skin. These antibodies bind to hemidesmosomal BP antigens

attracting inflammatory cells. There are reports available demonstrating plectin autoantibodies found in a few cases of blistering diseases (Fujiwara et al., 1996; Ohnishi et al., 2000).

Paraneoplastic pemphigus (PNP) is another autoimmune disorder characterized by severe mucosal erosions and various cutaneous lesions associated with lymphoproliferative neoplasms (Anhalt et al., 1990; Zhu and Zhang, 2007). PNP patients exhibit various autoantibodies to the plakin family proteins, namely envoplakin, periplakin, desmoplakin I-II, BPAG1 and plectin (Anhalt et al., 1990; Kim et al., 1997; Borradori et al., 1998; Mahoney et al., 1998; Nguyen et al., 2001).

Animal models

BPAG1e null mouse

Guo et al. targeted the removal of the BPAG1 encoding gene *DST* in mice to explore its protein function. They reported that HDs appeared normal but hemidesmosomal inner plate was absent. Furthermore, IF proteins were not attached to HDs due to which these BPAG1 null mice showed skin blistering. The BPAG1 null mice survived for 4-5 weeks. The localization of other hemidesmosomal proteins seemed unaffected by BPAG1 ablation. The mice also developed severe dystonia, myopathy and sensory nerve degeneration (Guo et al., 1995). This phenotype was observed due to inactivation of BPAG1a and BPAG1b, which act as linker proteins in neurons and skeletal muscles, respectively (Leung et al., 2001).

Plectin null mouse

Andra et al studied ablation of plectin in mice. Plectin knockout in mice resulted in cell degeneration. The skin was most severely affected in plectin knockout mice in which the dermis was separated from the epidermis and hence severe blistering was observed. The plectin null mice died 2-3 days after birth due to severe skin blistering. The DSs and HDs were found to be normal ultrastructurally. However, the number of HDs was found to be significantly reduced. $\beta 4$ integrin levels were also reduced in plectin null mice. The reduction in number of HDs and $\beta 4$ integrin expression upon ablation of plectin indicated that plectin has role in a HD formation. Plectin null mice, unlike BPAG1e null mice, showed unaltered keratin filament formation indicating that absence of one linker protein is dispensable for other to anchor keratin proteins. Moreover, plectin null mice developed myopathy in skeletal muscle and disintegration of intercalated discs in the heart (Andra et al., 1997).

Altogether, these *in vivo* studies suggest that hemidesmosomal linker proteins are important for mechanical strengthening of the cell.

Table 1. Hereditary skin diseases of hemidesmosomal linker proteins.

Gene/ Protein	OMIM	Phenotype	Phenotype MIM	Mode of inheritance
PLEC1/ Plectin	113810	Epidermolysis bullosa simplex with pyloric atresia	612138	autosomal recessive
		Epidermolysis bullosa simplex, Ogna type	131950	autosomal dominant
		Epidermolysis bullosa simplex with muscular dystrophy	226670	autosomal recessive
		Muscular dystrophy, limb-girdle, type 2Q	613723	autosomal recessive
DST/ BPAG1	601282	Neuropathy, hereditary sensory and autonomic, type VI	614653	autosomal recessive
		Epidermolysis bullosa simplex, autosomal recessive 2	615425	autosomal recessive

Information adapted from <http://omim.org/>

Hemidesmosomal linker proteins and signaling

For the last two decades, there has been growing evidence which demonstrates that hemidesmosomal linker proteins play a role in cellular processes other than maintenance of tissue integrity.

BPAG1e

Apart from its known anchoring function, BPAG1e has been involved in various cellular processes.

BPAG1e and cell motility

In 1995, Guo et al. reported that BPAG1e null animals display impaired wound healing *in vivo*. The keratinocytes of BPAG1e null mice were not flattened, unlike those of normal migrating keratinocytes. The authors concluded that defects in migration may be attributed to retardation of initiation of migration of epidermal keratinocytes (Guo et al., 1995). This study indirectly implicates the role of BPAG1e in keratinocyte migration. One of the recent reports has shown that BPAG1e regulates keratinocyte migration by acting as a scaffold for $\beta 4$ integrin mediated modulation of Rac1 and cofilin activities. Additionally, BPAG1e ablation in keratinocytes resulted in aberrant motility and loss of front to rear polarity. Further, immunofluorescence studies have shown that BPAG1e and $\beta 4$ integrin colocalize at the leading edge of migrating keratinocytes indicating that $\beta 4$ integrin associated BPAG1e may have a role in keratinocyte migration (Hamill et al., 2009). A subsequent report from the same laboratory has demonstrated that BP180 plays a role in cell motility and lamellopodial stability by recruiting BPAG1e to $\alpha 6\beta 4$ integrin at the leading edge of the migrating keratinocytes (Hamill et al., 2011). On the other hand, Michael et al have shown reduced adhesion but increased spreading and migration in human keratinocytes carrying homozygous nonsense mutations in BPAG1e encoding gene. Altered levels of K14, $\beta 4$ integrin and $\beta 1$ integrin were also observed in these keratinocytes. Michael et al failed to reproduce similar findings in BPAG1e ablated normal keratinocytes (Michael et al., 2014). Taken together, it is difficult to conclude from these reports whether BPAG1e is a positive or negative regulator of cell motility and further research is necessary to resolve this issue.

BPAG1e and cancer

There are very few reports available related to altered BPAG1e expression in human cancers. A recent study from Shimbo et al demonstrated that autoantibodies against BPAG1e are found in higher amounts in the serum of patients with advanced melanoma. Thus, it can prove as potential biomarker for melanomas (Shimbo et al., 2010). In another study, it has been reported that upregulation of BPAG1e and $\alpha 6\beta 4$

integrin expression is found in invasive squamous cell carcinomas. Interestingly, these proteins were not localized to HDs and their pericellular localization was seen. Moreover, polarized localization of BPAG1e was lost in highly invasive tumours (Herold-Mende et al., 2001). Contrary, Lo et al have reported downregulated levels of hemidesmosomal components, including BPAG1e in nasopharyngeal carcinoma as compared to non-malignant nasopharyngeal epithelia (Lo et al., 2001). Thus, BPAG1e shows tissue dependent alterations during cancer development.

Plectin

Plectin has been implicated in various cellular processes. eg. dynamics of cytoskeletal proteins, cell migration etc.

Plectin and cytoskeletal stability

Plectin can interact with all three forms of cytoskeletal proteins. This might be the reason why destabilization of cellular integrity was more severe in plectin null mice compared to BPAG1e null mice. Plectin 1, 1a and 1c are expressed in human keratinocytes, of which only 1a isoform localizes specifically at the site of HDs. Moreover, only 1a isoform was capable of rescuing hemidesmosomal defects in plectin null keratinocytes (Andra et al., 2003). In another study, Valencia et al have recently shown that plectin 1c plays major role in a microtubule (MT) destabilization and hence decreased microtubule dynamics. Further, Enhanced MT stability due to ablation in plectin 1c led to changes in cell shape, nonpolarized cell migration, smaller sized focal adhesion contacts, higher glucose uptake and mitotic spindle aberrations combined with reduced growth rates of cells. The plectin-MT interaction antagonizes functions of microtubule associated proteins (MAPs), which are involved in MT stability and assembly (Valencia et al., 2013). Unlike plectin, other linker proteins like BPAG1 and ACF7 have been reported to have a role in stabilization of microtubules (Yang et al., 1999; Kodama et al., 2003). The role of plectin in regulation of actin cytoskeleton dynamics has also been reported. The actin cytoskeleton was found to be less extensive in plectin ablated cells as compared to wild type cells (Andra et al., 1998). These reports suggest that plectin is the first cytolinker protein having a role in both microtubule and microfilament destabilization. Together these observations suggest that plectin destabilizes microtubule and microfilament networks while other linker proteins like BPAG1 and ACF7 stabilize these networks.

Plectin, cancer and cell signaling

There are several studies indicating use of plectin as a potential biomarker in various cancer conditions (Kelly

Hemidesmosomal linker proteins

et al., 2008; Bausch et al., 2009, 2011; Lee et al., 2009; Pawar et al., 2011; Katada et al., 2012). The siRNA mediated knockdown of plectin resulted in decreased proliferation, migration and invasion of head and neck squamous cell carcinoma (HNSCC) cells. Moreover, in plectin knockdown cells phosphorylated ERK levels were decreased. Authors have argued that a decrease in cell migration and invasion may be attributed to a decrease in activity of ERK kinase. The exact mechanism by which these phenotypic changes took place is unclear. In addition, an inverse relation between expression of plectin in HNSCC and survival rate of patients was shown (Katada et al., 2012). In another study, plectin downregulation in colon carcinoma cells resulted in impairment of cell migration and adhesion. Plectin 1 and 1k were predominantly expressed in invasive colon carcinoma cells. Plectin 1k was targeted to actin rich podosome structures. Plectin knockdown inhibited assembly of these actin rich structures. Upon transfection of Plectin 1k N-terminus, actin rich structures were formed, indicating that plectin 1k has a role in podosome formation (McInroy and Maatta, 2011). In a recent study, gene expression profiling has revealed upregulation of plectin and type III IF protein, termed vimentin, in highly metastatic bladder cells as compared to low metastatic bladder cells. A dissociation of plectin-vimentin interaction in invasive bladder cancer cells resulted in impairment of invadopodia formation, reduced extracellular matrix degradation and metastasis (Sutoh Yoneyama et al., 2014). Under normal physiology, plectin is localized in the cytoplasm, while in pancreatic ductal adenocarcinoma (PDAC) its cell surface localization has been shown, which may be the result of trafficking through exosomes. The presence of plectin in exosomes from the serum of PDAC animals indicated that plectin can act as a potential serum marker (Shin et al., 2013).

Conclusion and future perspectives

In the last two decades, there has been a large increase in the understanding of the plakin family linker proteins. Several studies have shown that plakin proteins including BPAG1e and plectin are not present in the cells only to anchor specific proteins, but that they have functional a role in various cellular processes. The consequences of BPAG1e or plectin ablation in animals have given opportunities to explore insights related to these linker proteins. The biggest hurdle in studying HD dynamics in real time is the fact that true HDs are not formed in the majority of cultured cells. Further, very little is known about how HDs assemble and disassemble *in vivo*. The challenge remains to elucidate molecular mechanisms involved in HD stability. Recent studies have shown the role of hemidesmosomal linker proteins in various cellular processes other than their known anchoring function. For example, these proteins impact keratinocyte migration which is partly because they connect keratins to $\alpha 6 \beta 4$ integrin, which in turn

regulate several signaling pathways which are related to cell migration. In this connection, the challenge is to understand how and why these proteins are mislocalized in a cell to govern cellular migration. Moreover, it will be pertinent to find out whether inside-out or outside-in signaling mechanisms are responsible for this phenotype. To understand the role of linker proteins in various cellular processes we need to decipher interacting partners of these proteins which may provide clues regarding mechanism. Additionally, these plakin proteins have been reported as potential biomarkers in various cancer types. It would be interesting to understand their functions in the process of carcinogenesis. These studies would provide a platform for future applications in diagnostics and therapeutics.

References

- Aberdam D., Galliano M.F., Vailly J., Pulkkinen L., Bonifas J., Christiano A.M., Tryggvason K., Uitto J., Epstein E.H. Jr, Ortonne J.P. and Meneguzzi G. (1994). Herlitz's junctional epidermolysis bullosa is linked to mutations in the gene (*lamc2*) for the gamma 2 subunit of nicein/kalinin (laminin-5). *Nat. Genet.* 6, 299-304.
- Aho S. and Uitto J. (1998). Direct interaction between the intracellular domains of bullous pemphigoid antigen 2 (bp180) and beta 4 integrin, hemidesmosomal components of basal keratinocytes. *Biochem. Biophys. Res. Commun.* 243, 694-699.
- Andra K., Lassmann H., Bittner R., Shorny S., Fassler R., Propst F. and Wiche G. (1997). Targeted inactivation of plectin reveals essential function in maintaining the integrity of skin, muscle, and heart cytoarchitecture. *Genes Dev.* 11, 3143-3156.
- Andra K., Nikolic B., Stocher M., Drenckhahn D. and Wiche G. (1998). Not just scaffolding: Plectin regulates actin dynamics in cultured cells. *Genes Dev.* 12, 3442-3451.
- Andra K., Kornacker I., Jorgl A., Zorer M., Spazierer D., Fuchs P., Fischer I. and Wiche G. (2003). Plectin-isoform-specific rescue of hemidesmosomal defects in plectin (-/-) keratinocytes. *J. Invest. Dermatol.* 120, 189-197.
- Anhalt G.J., Kim S.C., Stanley J.R., Korman N.J., Jabs D.A., Kory M., Izumi H., Rattie H. 3rd, Mutasim D., Ariss-Abdo L. and Labib R.S. (1990). Paraneoplastic pemphigus. An autoimmune mucocutaneous disease associated with neoplasia. *N. Engl. J. Med.* 323, 1729-1735.
- Bausch D., Mino-Kenudson M., Fernandez-Del Castillo C., Warshaw A.L., Kelly K.A. and Thayer S.P. (2009). Plectin-1 is a biomarker of malignant pancreatic intraductal papillary mucinous neoplasms. *J. Gastrointest. Surg.* 13, 1948-1954.
- Bausch D., Thomas S., Mino-Kenudson M., Fernandez-del C.C., Bauer T.W., Williams M., Warshaw A.L., Thayer S.P. and Kelly K.A. (2011). Plectin-1 as a novel biomarker for pancreatic cancer. *Clin. Cancer Res.* 17, 302-309.
- Borradori L. and Sonnenberg A. (1999). Structure and function of hemidesmosomes: More than simple adhesion complexes. *J. Invest. Dermatol.* 112, 411-418.
- Borradori L., Koch P.J., Niessen C.M., Erkeland S., van Leusden M.R. and Sonnenberg A. (1997). The localization of bullous pemphigoid antigen 180 (bp180) in hemidesmosomes is mediated by its cytoplasmic domain and seems to be regulated by the beta4 integrin subunit. *J. Cell Biol.* 136, 1333-1347.
- Borradori L., Chavanas S., Schaapveld R.Q., Gagnoux-Palacios L.,

- Calafat J., Meneguzzi G. and Sonnenberg A. (1998). Role of the bullous pemphigoid antigen 180 (bp180) in the assembly of hemidesmosomes and cell adhesion--reexpression of bp180 in generalized atrophic benign epidermolysis bullosa keratinocytes. *Exp. Cell Res.* 239, 463-476.
- Bouameur J.E., Schneider Y., Begre N., Hobbs R.P., Lingasamy P., Fontao L., Green K.J., Favre B. and Borradori L. (2013). Phosphorylation of serine 4,642 in the c-terminus of plectin by mnk2 and pka modulates its interaction with intermediate filaments. *J. Cell Sci.* 126, 4195-4207.
- Brown T.A., Gil S.G., Sybert V.P., Lestringant G.G., Tadini G., Caputo R. and Carter W.G. (1996). Defective integrin alpha 6 beta 4 expression in the skin of patients with junctional epidermolysis bullosa and pyloric atresia. *J. Invest. Dermatol.* 107, 384-391.
- Chavanas S., Gache Y., Tadini G., Pulkkinen L., Uitto J., Ortonne J.P. and Meneguzzi G. (1997). A homozygous in-frame deletion in the collagenous domain of bullous pemphigoid antigen bp180 (type xvii collagen) causes generalized atrophic benign epidermolysis bullosa. *J. Invest. Dermatol.* 109, 74-78.
- de Pereda J.M., Ortega E., Alonso-Garcia N., Gomez-Hernandez M. and Sonnenberg A. (2009a). Advances and perspectives of the architecture of hemidesmosomes: Lessons from structural biology. *Cell Adh. Migr.* 3, 361-364.
- de Pereda J.M., Lillo M.P. and Sonnenberg A. (2009b). Structural basis of the interaction between integrin alpha6beta4 and plectin at the hemidesmosomes. *EMBO J.* 28, 1180-1190.
- Dowling J., Yu Q.C. and Fuchs E. (1996). Beta4 integrin is required for hemidesmosome formation, cell adhesion and cell survival. *J. Cell Biol.* 134, 559-572.
- Edvardson S., Cinnamon Y., J alas C., Shaag A., Maayan C., Axelrod F.B. and Elpeleg O. (2012). Hereditary sensory autonomic neuropathy caused by a mutation in dystonin. *Ann. Neurol.* 71, 569-572.
- Elliott C.E., Becker B., Oehler S., Castanon M.J., Hauptmann R. and Wiche G. (1997). Plectin transcript diversity: Identification and tissue distribution of variants with distinct first coding exons and rodless isoforms. *Genomics* 42, 115-125.
- Errante L.D., Wiche G. and Shaw G. (1994). Distribution of plectin, an intermediate filament-associated protein, in the adult rat central nervous system. *J. Neurosci. Res.* 37, 515-528.
- Fine J.D., Bauer E.A., Briggaman R.A., Carter D.M., Eady R.A., Esterly N.B., Holbrook K.A., Hurwitz S., Johnson L., Lin A., Pearson R. and Sybert V.P. (1991). Revised clinical and laboratory criteria for subtypes of inherited epidermolysis bullosa. A consensus report by the subcommittee on diagnosis and classification of the national epidermolysis bullosa registry. *J. Am. Acad. Dermatol.* 24, 119-135.
- Foisner R., Malecz N., Dressel N., Stadler C. and Wiche G. (1996). M-phase-specific phosphorylation and structural rearrangement of the cytoplasmic cross-linking protein plectin involve p34cdc2 kinase. *Mol. Biol. Cell* 7, 273-288.
- Fontao L., Favre B., Riou S., Geerts D., Jaunin F., Saurat J.H., Green K.J., Sonnenberg A. and Borradori L. (2003). Interaction of the bullous pemphigoid antigen 1 (bp230) and desmoplakin with intermediate filaments is mediated by distinct sequences within their cooh terminus. *Mol. Biol. Cell* 14, 1978-1992.
- Fuchs P., Zorer M., Rezniczek G.A., Spazierer D., Oehler S., Castanon M.J., Hauptmann R. and Wiche G. (1999). Unusual 5' transcript complexity of plectin isoforms: Novel tissue-specific exons modulate actin binding activity. *Hum. Mol. Genet.* 8, 2461-2472.
- Fujiwara S., Kohno K., Iwamatsu A., Naito I. and Shinkai H. (1996). Identification of a 450-kda human epidermal autoantigen as a new member of the plectin family. *J. Invest. Dermatol.* 106, 1125-1130.
- Geerts D., Fontao L., Nievers M.G., Schaapveld R.Q., Purkis P.E., Wheeler G.N., Lane E.B., Leigh I.M. and Sonnenberg A. (1999). Binding of integrin alpha6beta4 to plectin prevents plectin association with F-actin but does not interfere with intermediate filament binding. *J. Cell Biol.* 147, 417-434.
- Georges-Labouesse E., Messaddeq N., Yehia G., Cadalbert L., Dierich A. and Le Meur M. (1996). Absence of integrin alpha 6 leads to epidermolysis bullosa and neonatal death in mice. *Nat. Genet.* 13, 370-373.
- Giudice G.J., Emery D.J. and Diaz L.A. (1992). Cloning and primary structural analysis of the bullous pemphigoid autoantigen bp180. *J. Invest. Dermatol.* 99, 243-250.
- Green K.J., Virata M.L., Elgart G.W., Stanley J.R. and Parry D.A. (1992). Comparative structural analysis of desmoplakin, bullous pemphigoid antigen and plectin: Members of a new gene family involved in organization of intermediate filaments. *Int. J. Biol. Macromol.* 14, 145-153.
- Groves R.W., Liu L., Dopping-Hepenstal P.J., Markus H.S., Lovell P.A., Ozoemena L., Lai-Cheong J.E., Gawler J., Owaribe K., Hashimoto T., Mellerio J.E., Mee J.B. and McGrath J.A. (2010). A homozygous nonsense mutation within the dystonin gene coding for the coiled-coil domain of the epithelial isoform of bpag1 underlies a new subtype of autosomal recessive epidermolysis bullosa simplex. *J. Invest. Dermatol.* 130, 1551-1557.
- Guo L., Degenstein L., Dowling J., Yu Q.C., Wollmann R., Perman B. and Fuchs E. (1995). Gene targeting of bpag1: Abnormalities in mechanical strength and cell migration in stratified epithelia and neurologic degeneration. *Cell* 81, 233-243.
- Hamill K.J., Hopkinson S.B., DeBiase P. and Jones J.C. (2009). Bp180 maintains keratinocyte polarity through beta4 integrin-mediated modulation of rac1 and cofilin activities. *Mol. Biol. Cell* 20, 2954-2962.
- Hamill K.J., Hopkinson S.B., Jonkman M.F. and Jones J.C. (2011). Type xvii collagen regulates lamellipod stability, cell motility, and signaling to rac1 by targeting bullous pemphigoid antigen 1e to alpha6beta4 integrin. *J. Biol. Chem.* 286, 26768-26780.
- Herold-Mende C., Kartenbeck J., Tomakidi P. and Bosch F.X. (2001). Metastatic growth of squamous cell carcinomas is correlated with upregulation and redistribution of hemidesmosomal components. *Cell Tissue Res.* 306, 399-408.
- Hieda Y., Nishizawa Y., Uematsu J. and Owaribe K. (1992). Identification of a new hemidesmosomal protein, hd1: A major, high molecular mass component of isolated hemidesmosomes. *J. Cell Biol.* 116, 1497-1506.
- Hopkinson S.B. and Jones J.C. (2000). The n terminus of the transmembrane protein bp180 interacts with the n-terminal domain of bp230, thereby mediating keratin cytoskeleton anchorage to the cell surface at the site of the hemidesmosome. *Mol. Biol. Cell* 11, 277-286.
- Hopkinson S.B., Baker S.E. and Jones J.C. (1995). Molecular genetic studies of a human epidermal autoantigen (the 180-kd bullous pemphigoid antigen/bp180): Identification of functionally important sequences within the bp180 molecule and evidence for an interaction between bp180 and alpha 6 integrin. *J. Cell Biol.* 130, 117-125.
- Hopkinson S.B., Findlay K., deHart G.W. and Jones J.C. (1998).

Hemidesmosomal linker proteins

- Interaction of bp180 (type xvii collagen) and alpha6 integrin is necessary for stabilization of hemidesmosome structure. *J. Invest. Dermatol.* 111, 1015-1022.
- Jones J.C., Hopkinson S.B. and Goldfinger L.E. (1998). Structure and assembly of hemidesmosomes. *Bioessays* 20, 488-494.
- Jonkman M.F., de Jong M.C., Heeres K., Pas H.H., van der Meer J.B., Owaribe K., Martinez de Velasco A.M., Niessen C.M. and Sonnenberg A. (1995). 180-kd bullous pemphigoid antigen (bp180) is deficient in generalized atrophic benign epidermolysis bullosa. *J. Clin. Invest.* 95, 1345-1352.
- Jordon R.E., Beutner E.H., Witebsky E., Blumental G., Hale W.L. and Lever W.F. (1967). Basement zone antibodies in bullous pemphigoid. *JAMA* 200, 751-756.
- Katada K., Tomonaga T., Satoh M., Matsushita K., Tonoike Y., Kodera Y., Hanazawa T., Nomura F. and Okamoto Y. (2012). Plectin promotes migration and invasion of cancer cells and is a novel prognostic marker for head and neck squamous cell carcinoma. *J. Proteomics* 75, 1803-1815.
- Kelly K.A., Bardeesy N., Anbazhagan R., Gurumurthy S., Berger J., Alencar H., Depinho R.A., Mahmood U. and Weissleder R. (2008). Targeted nanoparticles for imaging incipient pancreatic ductal adenocarcinoma. *PLoS Med.* 5, e85.
- Kim S.C., Kwon Y.D., Lee I.J., Chang S.N. and Lee T.G. (1997). Cdna cloning of the 210-kda paraneoplastic pemphigus antigen reveals that envoplakin is a component of the antigen complex. *J. Invest. Dermatol.* 109, 365-369.
- Kodama A., Karakesisoglou I., Wong E., Vaezi A. and Fuchs E. (2003). Acl7: An essential integrator of microtubule dynamics. *Cell* 115, 343-354.
- Koss-Harnes D., Hoyheim B., Anton-Lamprecht I., Gjesti A., Jorgensen R.S., Jahnsen F.L., Olaisen B., Wiche G. and Gedde-Dahl T. Jr (2002). A site-specific plectin mutation causes dominant epidermolysis bullosa simplex ogna: Two identical de novo mutations. *J. Invest. Dermatol.* 118, 87-93.
- Koster J., Kuikman I., Kreft M. and Sonnenberg A. (2001). Two different mutations in the cytoplasmic domain of the integrin beta 4 subunit in nonlethal forms of epidermolysis bullosa prevent interaction of beta 4 with plectin. *J. Invest. Dermatol.* 117, 1405-1411.
- Koster J., Geerts D., Favre B., Borradori L. and Sonnenberg A. (2003). Analysis of the interactions between bp180, bp230, plectin and the integrin alpha6beta4 important for hemidesmosome assembly. *J. Cell Sci.* 116, 387-399.
- Koster J., van Wilpe S., Kuikman I., Litjens S.H. and Sonnenberg A. (2004). Role of binding of plectin to the integrin beta4 subunit in the assembly of hemidesmosomes. *Mol. Biol. Cell* 15, 1211-1223.
- Labib R.S., Anhalt G.J., Patel H.P., Mutasim D.F. and Diaz L.A. (1986). Molecular heterogeneity of the bullous pemphigoid antigens as detected by immunoblotting. *J. Immunol.* 136, 1231-1235.
- Lee H.J., Na K., Kwon M.S., Kim H., Kim K.S. and Paik Y.K. (2009). Quantitative analysis of phosphopeptides in search of the disease biomarker from the hepatocellular carcinoma specimen. *Proteomics* 9, 3395-3408.
- Leung C.L., Zheng M., Prater S.M. and Liem R.K. (2001). The bpag1 locus: Alternative splicing produces multiple isoforms with distinct cytoskeletal linker domains, including predominant isoforms in neurons and muscles. *J. Cell Biol.* 154, 691-697.
- Leung C.L., Green K.J. and Liem R.K. (2002). Plakins: A family of versatile cytolinker proteins. *Trends Cell Biol.* 12, 37-45.
- Liu Z., Diaz L.A., Troy J.L., Taylor A.F., Emery D.J., Fairley J.A. and Giudice G.J. (1993). A passive transfer model of the organ-specific autoimmune disease, bullous pemphigoid, using antibodies generated against the hemidesmosomal antigen, bp180. *J. Clin. Invest.* 92, 2480-2488.
- Lo A.K., Yuen P.W., Liu Y., Wang X.H., Cheung A.L., Wong Y.C. and Tsao S.W. (2001). Downregulation of hemidesmosomal proteins in nasopharyngeal carcinoma cells. *Cancer Lett.* 163, 117-123.
- Mahoney M.G., Aho S., Uitto J. and Stanley J.R. (1998). The members of the plakin family of proteins recognized by paraneoplastic pemphigus antibodies include periplakin. *J. Invest. Dermatol.* 111, 308-313.
- McGrath J.A., Gatalica B., Christiano A.M., Li K., Owaribe K., McMillan J.R., Eady R.A. and Uitto J. (1995). Mutations in the 180-kd bullous pemphigoid antigen (bpag2), a hemidesmosomal transmembrane collagen (col17a1), in generalized atrophic benign epidermolysis bullosa. *Nat. Genet.* 11, 83-86.
- McInroy L. and Maatta A. (2011). Plectin regulates invasiveness of sw480 colon carcinoma cells and is targeted to podosome-like adhesions in an isoform-specific manner. *Exp. Cell Res.* 317, 2468-2478.
- Michael M., Begum R., Fong K., Pourreyron C., South A.P., McGrath J.A. and Parsons M. (2014). Bpag1-e restricts keratinocyte migration through control of adhesion stability. *J. Invest. Dermatol.* 134, 773-782.
- Mueller S., Klaus-Kovtun V. and Stanley J.R. (1989). A 230-kd basic protein is the major bullous pemphigoid antigen. *J. Invest. Dermatol.* 92, 33-38.
- Murgia C., Blaikie P., Kim N., Dans M., Petrie H.T. and Giancotti F.G. (1998). Cell cycle and adhesion defects in mice carrying a targeted deletion of the integrin beta4 cytoplasmic domain. *EMBO J.* 17, 3940-3951.
- Nakano A., Pulkkinen L., Murrell D., Rico J., Lucky A.W., Garzon M., Stevens C.A., Robertson S., Pfendner E. and Uitto J. (2001). Epidermolysis bullosa with congenital pyloric atresia: Novel mutations in the beta 4 integrin gene (itgb4) and genotype/phenotype correlations. *Pediatr. Res.* 49, 618-626.
- Nguyen V.T., Ndoye A., Bassler K.D., Shultz L.D., Shields M.C., Ruben B.S., Webber R.J., Pittelkow M.R., Lynch P.J. and Grando S.A. (2001). Classification, clinical manifestations, and immunopathological mechanisms of the epithelial variant of paraneoplastic autoimmune multiorgan syndrome: A reappraisal of paraneoplastic pemphigus. *Arch. Dermatol.* 137, 193-206.
- Niemi K.M., Sommer H., Kero M., Kanerva L. and Haltia M. (1988). Epidermolysis bullosa simplex associated with muscular dystrophy with recessive inheritance. *Arch. Dermatol.* 124, 551-554.
- Niessen C.M., Hulsman E.H., Oomen L.C., Kuikman I. and Sonnenberg A. (1997a). A minimal region on the integrin beta4 subunit that is critical to its localization in hemidesmosomes regulates the distribution of hd1/plectin in cos-7 cells. *J. Cell Sci.* 110, 1705-1716.
- Niessen C.M., Hulsman E.H., Rots E.S., Sanchez-Aparicio P. and Sonnenberg A. (1997b). Integrin alpha 6 beta 4 forms a complex with the cytoskeletal protein hd1 and induces its redistribution in transfected cos-7 cells. *Mol. Biol. Cell* 8, 555-566.
- Nievers M.G., Schaapveld R.Q., Oomen L.C., Fontao L., Geerts D. and Sonnenberg A. (1998). Ligand-independent role of the beta 4 integrin subunit in the formation of hemidesmosomes. *J. Cell Sci.* 111, 1659-1672.
- Nievers M.G., Schaapveld R.Q. and Sonnenberg A. (1999). Biology and function of hemidesmosomes. *Matrix Biol.* 18, 5-17.

- Nievers M.G., Kuikman I., Geerts D., Leigh I.M. and Sonnenberg A. (2000). Formation of hemidesmosome-like structures in the absence of ligand binding by the $\alpha 6 \beta 4$ integrin requires binding of hd1/plectin to the cytoplasmic domain of the $\beta 4$ integrin subunit. *J. Cell Sci.* 113 (Pt 6), 963-973.
- Nishizawa Y., Uematsu J. and Owaribe K. (1993). Hd4, a 180 kda bullous pemphigoid antigen, is a major transmembrane glycoprotein of the hemidesmosome. *J. Biochem.* 113, 493-501.
- Ohnishi Y., Tajima S., Ishibashi A. and Fujiwara S. (2000). A vesicular bullous pemphigoid with an autoantibody against plectin. *Br. J. Dermatol.* 142, 813-815.
- Pawar H., Kashyap M.K., Sahasrabudhe N.A., Renuse S., Harsha H.C., Kumar P., Sharma J., Kandasamy K., Marimuthu A., Nair B., Rajagopalan S., Maharudraiah J., Premalatha C.S., Kumar K.V., Vijayakumar M., Chaerkady R., Prasad T.S., Kumar R.V. and Pandey A. (2011). Quantitative tissue proteomics of esophageal squamous cell carcinoma for novel biomarker discovery. *Cancer Biol. Ther.* 12, 510-522.
- Pearson R.W. (1962). Studies on the pathogenesis of epidermolysis bullosa. *J. Invest. Dermatol.* 39, 551-575.
- Reznicek G.A., de Pereda J.M., Reipert S. and Wiche G. (1998). Linking integrin $\alpha 6 \beta 4$ -based cell adhesion to the intermediate filament cytoskeleton: Direct interaction between the $\beta 4$ subunit and plectin at multiple molecular sites. *J. Cell Biol.* 141, 209-225.
- Sawamura D., Li K., Chu M.L. and Uitto J. (1991). Human bullous pemphigoid antigen (bpag1). Amino acid sequences deduced from cloned cdnas predict biologically important peptide segments and protein domains. *J. Biol. Chem.* 266, 17784-17790.
- Schaapveld R.Q., Borradori L., Geerts D., van Leusden M.R., Kuikman I., Nievers M.G., Niessen C.M., Steenbergen R.D., Sniijders P.J. and Sonnenberg A. (1998). Hemidesmosome formation is initiated by the $\beta 4$ integrin subunit, requires complex formation of $\beta 4$ and hd1/plectin, and involves a direct interaction between $\beta 4$ and the bullous pemphigoid antigen 180. *J. Cell Biol.* 142, 271-284.
- Shimbo T., Tanemura A., Yamazaki T., Tamai K., Katayama I. and Kaneda Y. (2010). Serum anti-bpag1 auto-antibody is a novel marker for human melanoma. *PLoS One* 5, e10566.
- Shin S.J., Smith J.A., Reznicek G.A., Pan S., Chen R., Brentnall T.A., Wiche G. and Kelly K.A. (2013). Unexpected gain of function for the scaffolding protein plectin due to mislocalization in pancreatic cancer. *Proc. Natl. Acad. Sci. USA* 110, 19414-19419.
- Skalli O., Chou Y.H. and Goldman R.D. (1992). Cell cycle-dependent changes in the organization of an intermediate filament-associated protein: Correlation with phosphorylation by p34cdc2. *Proc. Natl. Acad. Sci. USA* 89, 11959-11963.
- Stanley J.R., Hawley-Nelson P., Yuspa S.H., Shevach E.M. and Katz S.I. (1981). Characterization of bullous pemphigoid antigen: A unique basement membrane protein of stratified squamous epithelia. *Cell* 24, 897-903.
- Stanley J.R., Woodley D.T. and Katz S.I. (1984). Identification and partial characterization of pemphigoid antigen extracted from normal human skin. *J. Invest. Dermatol.* 82, 108-111.
- Stepp M.A., Spurr-Michaud S., Tisdale A., Elwell J. and Gipson I.K. (1990). $\alpha 6 \beta 4$ integrin heterodimer is a component of hemidesmosomes. *Proc. Natl. Acad. Sci. USA* 87, 8970-8974.
- Sterk L.M., Geuijen C.A., Oomen L.C., Calafat J., Janssen H. and Sonnenberg A. (2000). The tetraspan molecule cd151, a novel constituent of hemidesmosomes, associates with the integrin $\alpha 6 \beta 4$ and may regulate the spatial organization of hemidesmosomes. *J. Cell Biol.* 149, 969-982.
- Sun D., Leung C.L. and Liem R.K. (2001). Characterization of the microtubule binding domain of microtubule actin crosslinking factor (macf): Identification of a novel group of microtubule associated proteins. *J. Cell Sci.* 114, 161-172.
- Sutoh Yoneyama M., Hatakeyama S., Habuchi T., Inoue T., Nakamura T., Funyu T., Wiche G., Ohyama C. and Tsuboi S. (2014). Vimentin intermediate filament and plectin provide a scaffold for invadopodia, facilitating cancer cell invasion and extravasation for metastasis. *Eur. J. Cell Biol.* 93, 157-169.
- Valencia R.G., Walko G., Janda L., Novacek J., Mihailovska E., Reipert S., Andra-Marobela K. and Wiche G. (2013). Intermediate filament-associated cytolinker plectin 1c destabilizes microtubules in keratinocytes. *Mol. Biol. Cell* 24, 768-784.
- van der Neut R., Krimpenfort P., Calafat J., Niessen C.M. and Sonnenberg A. (1996). Epithelial detachment due to absence of hemidesmosomes in integrin $\beta 4$ null mice. *Nat. Genet.* 13, 366-369.
- Walko G., Vukasinovic N., Gross K., Fischer I., Sibitz S., Fuchs P., Reipert S., Jungwirth U., Berger W., Salzer U., Carugo O., Castanon M.J. and Wiche G. (2011). Targeted proteolysis of plectin isoform 1a accounts for hemidesmosome dysfunction in mice mimicking the dominant skin blistering disease ebs-ogna. *PLoS Genet.* 7, e1002396.
- Yang Y., Bauer C., Strasser G., Wollman R., Julien J.P. and Fuchs E. (1999). Integrators of the cytoskeleton that stabilize microtubules. *Cell* 98, 229-238.
- Zhu X. and Zhang B. (2007). Paraneoplastic pemphigus. *J. Dermatol.* 34, 503-511.
- Zillikens D. (1999). Acquired skin disease of hemidesmosomes. *J. Dermatol. Sci.* 20, 134-154.