

Organiza:



V ENCUESTRO Ingeniería de la Energía

Patrocinadores:



Asociación Nacional
de Productores
de Energía Renovable



Cátedra
Takasago Industria y
Mantenimiento 4.0



CÁTEDRA DEL AGUA
Y LA SOSTENIBILIDAD



ACTAS DEL CONGRESO

V ENCUESTRO DE INGENIERÍA DE LA ENERGÍA DEL CAMPUS MARE NOSTRUM



Editores:

Mariano Alarcón García (Editor)

Manuel Seco Nicolás (Co-editor)

© Mariano Alarcón García

ISBN: 978-84-09-29971-3

Dirección web de congreso: V-EIECMN

Universidad de Murcia

Campus Mare Nostrum

Del 23 al 26 de
noviembre de 2020

Quinta edición del Encuentro orientado a servir de espacio de reunión para tratar las distintas facetas de las aplicaciones de la Energía en los ámbitos académico y profesional, así como de instituciones y empresas en el que compartir trabajos, se muestren avances creando un espacio virtual de debate y reflexión en el que plantear soluciones a los importantes retos que la Sociedad tiene en el ámbito de la Energía, englobado en el ODS-7, *Energía asequible y no contaminante*, desde una vocación tecnológica pero a la vez con sensibilidad social.





NUMERICAL CHARACTERIZATION OF A CO₂ WATER HEATER HEAT PUMP ACCORDING TO SPANISH NORM UNE-EN 16147

Mohammed Réda Haddouche ^(1*); José Ramón García Cascales ⁽¹⁾

Fernando Illan Gómez ⁽²⁾; Francisco Javier Sánchez Velasco ⁽³⁾

mohammedreda.haddouche@edu.upct.es *

⁽¹⁾ ⁽²⁾ ⁽³⁾ ⁽⁴⁾ Universidad Politécnica de Cartagena, ETS de Ingeniería Industrial, Laboratorio de Frio y Calor

ABSTRACT

Ensuring a reliable, economical and sustainable energy supply as well as environmental and climate protection are important global challenges of the 21st century. Renewable energies and improving energy efficiency are the most important steps to achieve these energy policy goals. The use of CO₂ heat pumps for hot water production has a great economic and environmental benefit regarding its energetic performance. A new model of a stratified storage tank is developed in our laboratory using FORTRAN developer studio and its simulation is conducted using TRNSYS simulation studio.

Key words: CO₂ heat pump; TRNSYS numerical simulation, energetic efficiency.

1. Introducción

Nowadays heat pumps can be considered a solution to replace fossil fuels and can be considered as an alternative source of energy. A stratified storage tank is highly recommended for heat pumps water heaters in order to maintain a high energetic performance [1, 2]. Moreover, many researchers in this field focus on the development of high efficiency CO₂ heat pump. Zhihua Wang et al. [3, 4] analysed numerically the performance of a CO₂ heat pump for residential heating system using TRNSYS. Sung Goo Kim et al. [5] investigated numerically and experimentally the influence of a heat exchanger on the performance of a trans-critical CO₂ cycle. Ryohei Yokoyama et al. [6] analysed numerically the influence of the hot water demand on the performance of a CO₂ heat pump. Lingxiao Yang et al. [7] studied experimentally an air-source trans-critical CO₂ heat pump water heater under different working conditions.

In this paper a new numerical model of a stratified storage tank was conducted to investigate a system for hot water production using CO₂ heat pumps and analyse its energetic and thermal performance under the Spanish norm.

2. Numerical model

A new model of a stratified storage tank is developed in our laboratory using FORTRAN developer studio. This model is based on the finite difference method considering the convection and conduction heat transfer inside and outside the tank; free convection between the environment and the outer wall of the tank [8], molecular conduction between the stratified layers inside the tank, mixed convection-conduction between the inner wall of the tank and the fluid. The radiation is neglected in this model. The mass conservation and the energy balance equations are applied to secure the fluid flow inside the tank. The numerical simulation of the heat pump water heater was conducted using TRNSYS simulation studio.

3. Model validation

For this purpose the new stratified storage tank type_263 model is compared with the TRNSYS library model type_4 as shown in figure 1.

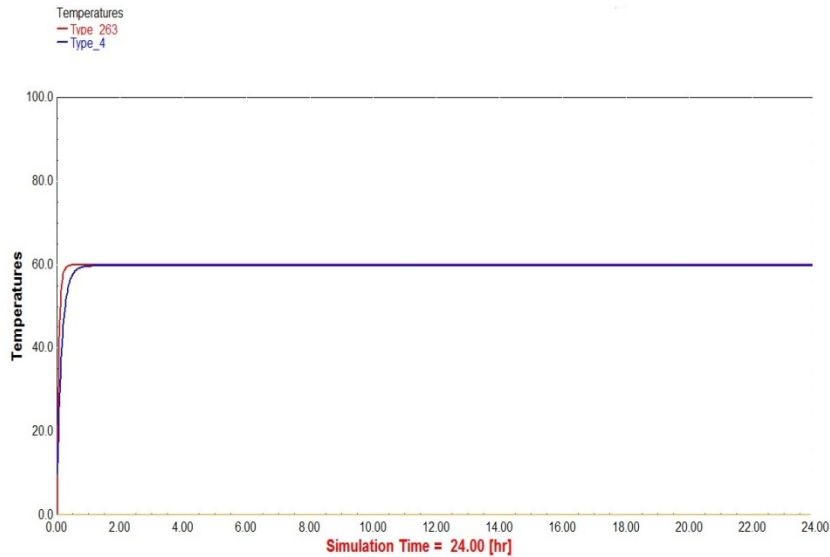

Figure 1: Comparison between the type_4 and type_263.

It can be seen from the figure 1 that the two models agree well with each other with a slightly deviation.

4. Results and discussion

Figure 2 shows the schematic diagram of TRNSYS program for a CO2 water heater heat pump connected to the hot water circuit.

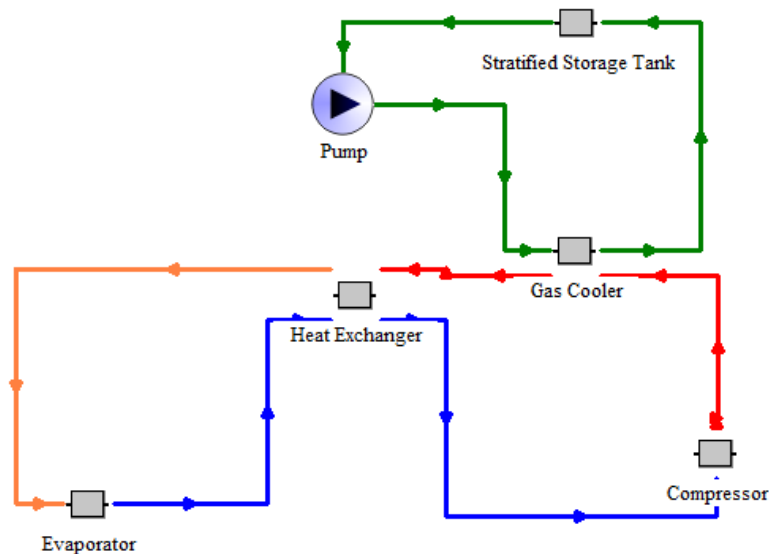

Figure 1: The schematic diagram of the heat pump water loop.



The simulation principle is producing hot water with a CO₂ heat pump, with the initial temperature of 10°C and a fixed flow rate of 0.3 kg/s for both models. Figure 3 shows the numerical result of the hot water production at different levels.

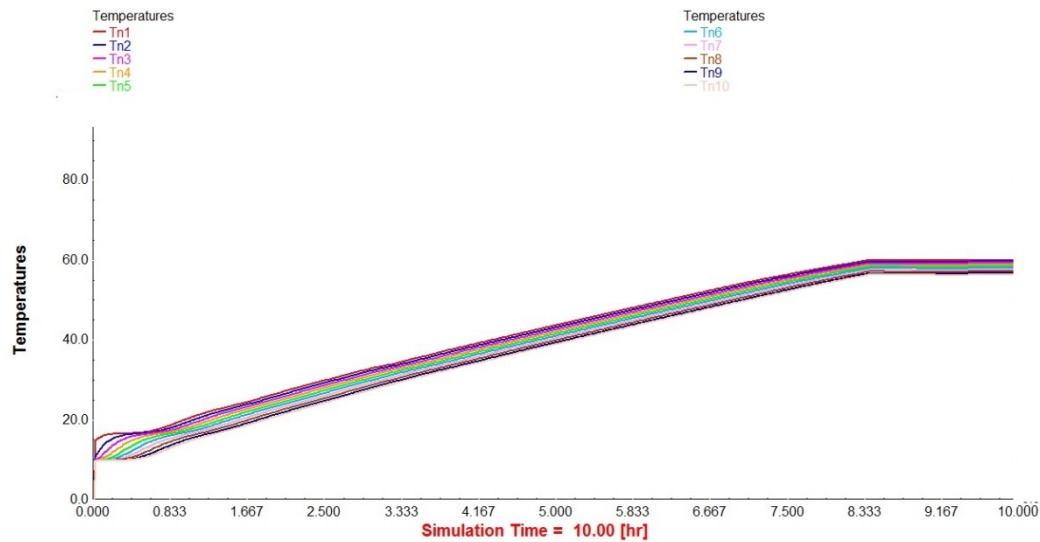

Figure 3: temperature evolution as a function of time.

Figure 3 shows the temperatures evolution as a function of time. It can be seen from this figure that the temperature reaches the 60°C at 8 hours and the entire tank has the same temperature.

5. Conclusion

In this paper a new stratified hot water storage tank model was presented. The numerical results show a good agreement between the new model and the TRNSYS library model. The numerical results of the water heating using the CO₂ heat pump take 8 hours to reach 60°C under specified conditions.

6. Agradecimientos

This work is a first part of the project conducted in the laboratory of "Frio y calor" at the UPCT to analyse numerically and experimentally an installation for hot water production using CO₂ heat pump under the Spanish norm.

7. Referencias

- [1] H. O. Njoku; O. V. Ekechukwu; S. O. Onyegebu. *Analysis of stratified thermal storage systems: An overview* Heat and Mass Transfer, 2014, vol. 50, pp. 1017-1030.
- [2] Juanli Ma; Alan S. Fung; Monica Brands; Neil Juan; Osama Mohammad Abul Moyeed. *Performance analysis of indirect-expansion solar assisted heat pump using CO₂ as refrigerant for space heating in cold climate*. Journal of Solar Energy, 2020, núm 187. 195, 205.



- [3] Zhihua Wang; Fenghao Wang; Zhenjun Ma; Wenye Lin; Haoshan Ren. *Investigation on the feasibility and performance of transcritical CO₂ heat pump integrated with thermal energy storage for space heating*. Renewable Energy, 2019, núm 134. 496, 508.
- [4] Zhihua Wang; Fenghao Wang; Zhenjun Ma; Wenye Lin; Haoshan Ren. *Study on performance evaluation of CO₂ heat pump system integrated with thermal energy storage for space heating*. Energy procediaa, 2019, núm 158. 1380, 1387.
- [5] Sung Goo Kim; Yoon Jo Kim; Gilbong Lee; Min Soo Kim. *The performance of a transcritical CO₂ cycle with an internal heatexchanger for hot water heating*. Internatinal journal of refrigeration, 2015, núm 28. 1064, 1072.
- [6] Ryohei Yokoyama; Tetsuya Wakui ; Junya Kamakari; Kazuhisa Takemura. *Performance analysis of a CO₂ heat pump water heating system under a daily change in a standardized demand*. Energy , 2010, núm 35. 718, 728.
- [7] Lingxiao Yanga; Xiang Qina; Linghua Zhaoa; Song Yea; Xinli Weia; Dongwei Zhang. *Analysis and comparison of influence factors of hot water temperature in transcritical CO₂ heat pump water heater*. Energy conversion and management , 2019, núm 198.
- [8] T. Fujh, m;Ttakeuchi, m; fujh, K. suzaki ; H. Uehara. *Experiments on natural-convection heat transfer from the outer surface of avertical cylinder to liquids*. Internatinal journal of heat and mass transfer , 1968, núm 13. 753, 787.



Comités del V Congreso Encuentro de Ingeniería de la Energía del Campus Mare Nostrum

Comité organizador

Mariano Alarcón García (Presidente)
Manuel Seco Nicolás
Francisco del Cerro Velázquez
Juan Pedro Luna Abad
Alfonso P. Ramallo González
Fernando Lozano Rivas

Comité científico

Alfonso P. Ramallo González (UM)
Antonia Baeza Caracena (UM)
Antonio González Carpena (UM)
Antonio Urbina Yeregui (UPCT)
Antonio Viedma Robles (UPCT)
Félix Cesáreo Gómez de León Hijes (UM)
Fernando Illán Gómez (UPCT)
Francisco del Cerro Velázquez (UM)
Francisco Vera García (UPCT)
Gloria Alarcón García (UM)
Gloria Villora Cano (UM)
Joaquín Zueco Jordán (UPCT)
José A. Almendros Ibáñez (UCLM)
José Miguel Martínez Paz (UM)
José Ramón García Cascales (UPCT)
Juan Pedro Luna Abad (UPCT)
Juan Pedro Montávez Gómez (UM)
Manuel Lucas Miralles (UMH)
Manuel Seco Nicolás (UM)
Mariano Alarcón García (UM)
Miguel Ángel Zamora Izquierdo (UM)
Pedro J. Vicente Quiles (UMH)
Teresa Maria Navarro Caballero (UM)
Teresa Vicente Vicente (UM)

ley. Dirijase a CEDRO (Centro Español de Derechos Reprográficos, www.cedro.org) si necesita fotocopiar o escanear algún fragmento de esta obra.

**ACTAS DEL CONGRESO V ENCUENTRO DE
INGENIERÍA DE LA ENERGÍA DEL CAMPUS MARE
NOSTRUM**

**PROCEEDINGS OF THE V MEETING OF ENERGY ENGINEERING OF
CAMPUS MARE NOSTRUM**

Editor

Mariano Alarcón García

Co-editor

Manuel Seco Nicolás

Murcia 2021